



Planbureau voor de Leefomgeving

A comprehensive view on climate change: Coupling of Earth System and Integrated Assessment Models

Detlef P. van Vuuren, Laura Batlle Bayer,
Clifford Chuwah, Laurens Ganzeveld,
Wilco Hazeleger, Bart van den Hurk,
Twan van Noije, Brian O'Neill, Bart J.
Strengers



Climate change multi-facet topic - traditionally studied from different disciplines

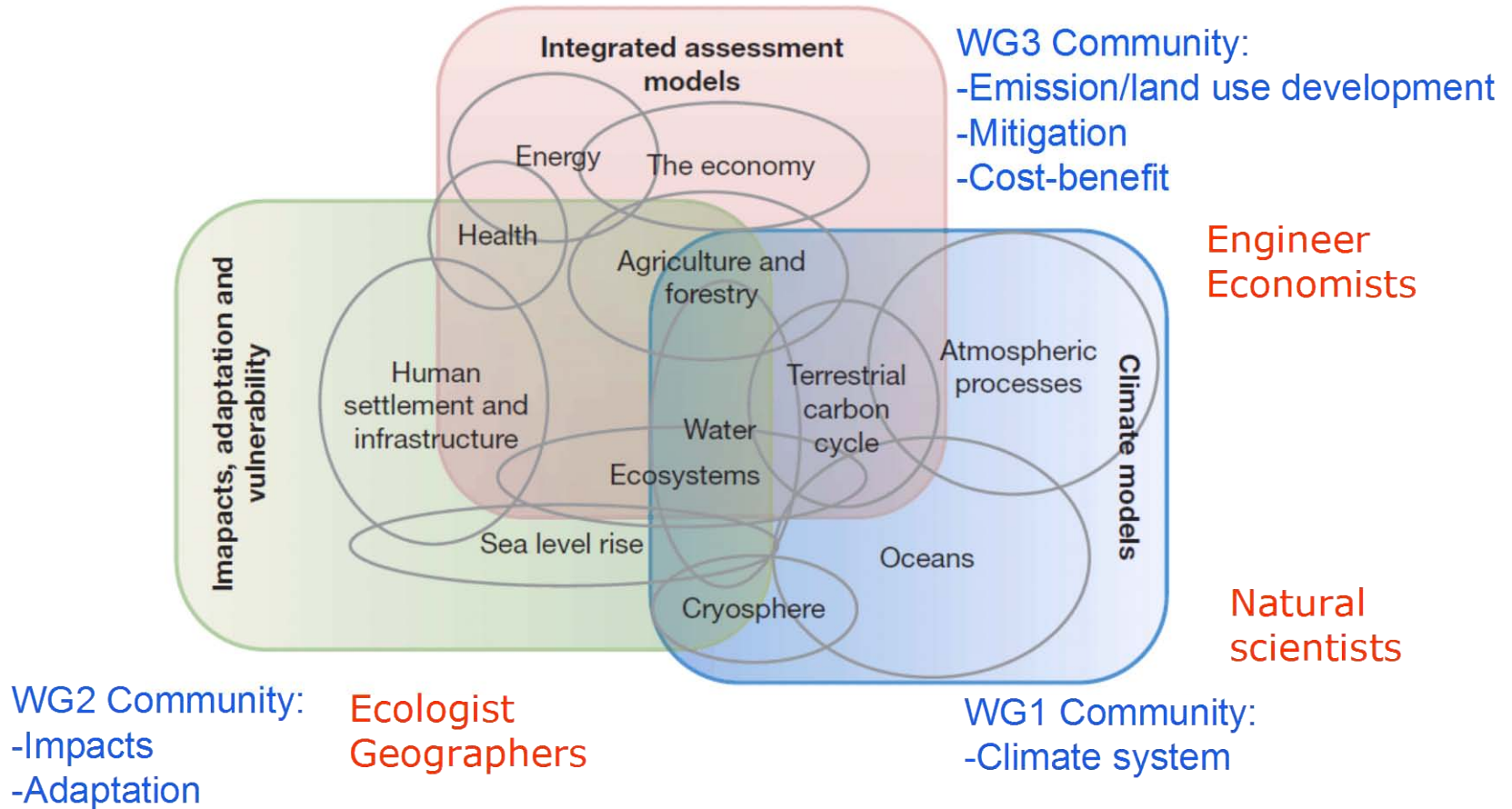



Always has been cooperation, but recent trend seems to be towards more integration

Reasons

- Discussion about costs and benefits of climate change
- ES Models: Climate → ... + carbon cycle → ... + land cover → ... + land use + water etc. → More-and-more factors determine ESM outcomes that were traditionally more “IAM” topics.
- New scenarios as “common thread” to link different WGs IPCC better together
- ...

Examples

1. Common projects IMAGE – EC Earth; IMAGE – NCAR; PNNL – NCAR
2. Joint papers on research agenda (eg. Hibbard et al. for land-use)
3. Voldoire et al.; Bahn et al

How to organize cooperation?

Focus here on the linkages of IAM and ES model

Default mode in discussions seem to be further model expansion → include IAM aspects into ES models

Is that a clever strategy?

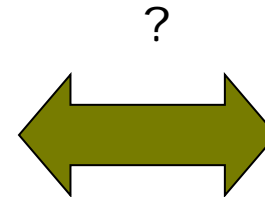
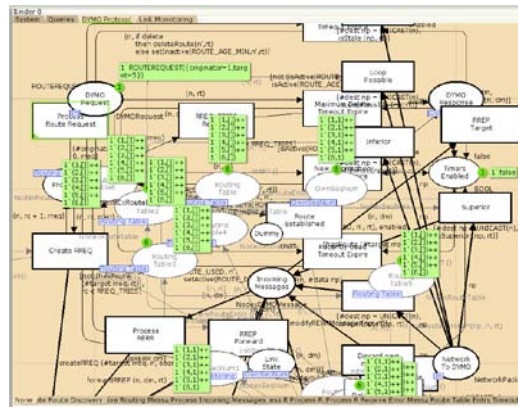

CALM DOWN

How to organize cooperation?

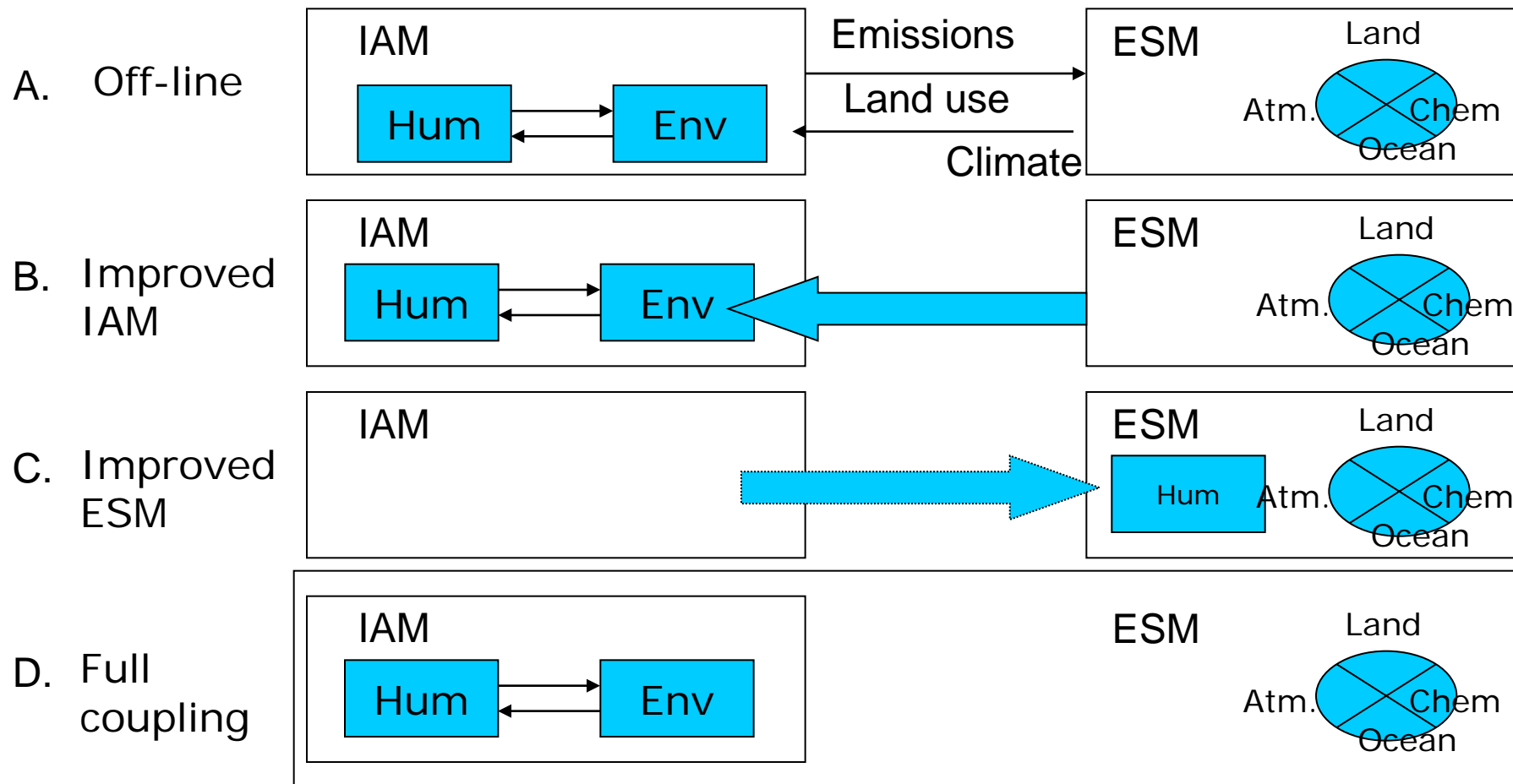

Cooperation type A.

- Comparable to current set-up CMIP5/RCPs
 - work with existing terminology and tools
 - transparent information exchange
 - High flexibility : easy exchange of ESMs and IAMs
 - separate research strategies
- Feedbacks are only captured via (one-single) iterations.
- potential inconsistencies

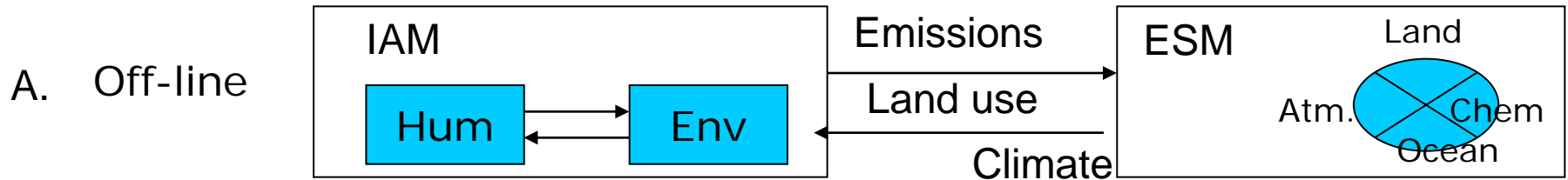

Cooperation type B.

- Further improve climate models in ESM (MAGICC emulation of CMIP4 models; pattern scaling; refined pattern scaling (sulphur, albedo etc))
 - IAMs designed as integration platform
 - allows for good representation of uncertainty
 - Flexibility : different ESM might be represented
 - model complexity tailored to question
 - detail in treatment of socio-economic processes
- lack of detail in treatment of biophysical processes (often meta modeling)

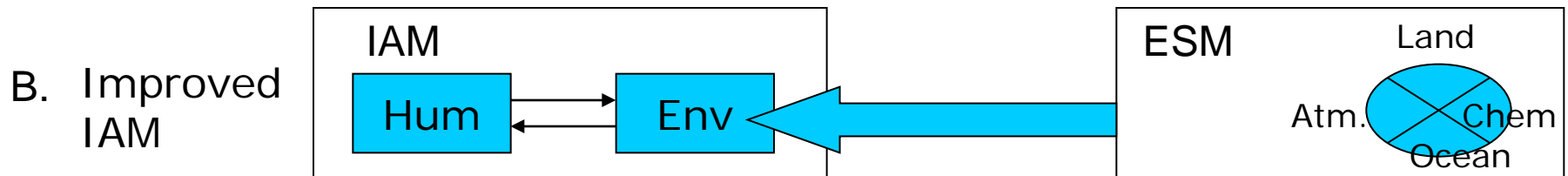

Cooperation type C.

- Further include human system elements in ESMs (e.g. urban environment, land-use rules to better describe land-cover, water consumption rules)
- higher resolution analyses than in IAMs
- detail in treatment of biophysical processes
- lack of detail in treatment of socio-economic processes
- limitation of model runs limits representation of uncertainty

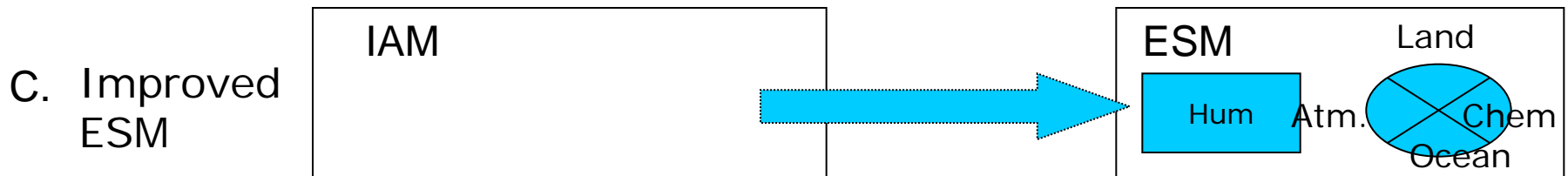

Cooperation type D.

- Include full IAMs in ESMs (e.g. IMAGE in CNRM-CM3, Voldoire et al; GCAM in CCSM etc).
- assessment of feedbacks
- highest degree of consistency
- technical difficulties
- Complex cooperation
- lack of representation of uncertainty
- Inflexibility (one IAM, one ESM)
- complexity/intransparency
- limitations in knowledge may hamper progress

D. Full coupling





Consideration for best form of cooperation

- One-way linkage dominant (feedbacks are weak, very slow, or non-existent) → category A
- Interactions significant in both directions and simple formulation possible → category B (e.g. radiative forcing by long-lived greenhouse gases)
- Main focus natural system; simple human system representation possible → category C (e.g. land-use rules)
- Interactions (likely) significant and processes are complex (geographical, temporal) and/or cannot be adequately represented in simple models → category D.
- Non-linear threshold behavior --> category D?
- Uncertainty very large? → category A or B, at least to explore uncertainty range. Only if results indicate possible strong feedback → C or D analysis.
- In other words, it is only useful to consider complex coupling if potentially strong feedbacks are involved and the processes involved are rather well established.

Examples

- *Impact of climate change on energy use.* Relatively well-known, but mostly via aggregated processes (see Isaac et al, Aebischer et al, Hadley et al). Small impacts (thus category B?). Maybe impacts via air pollution could warrant more complex interactions (first exploration via A)?
- *Impact of climate change on transport and shipping routes.* More uncertain, but global impacts likely to be small (Eyring et al.). Coupling via A.
- *Interaction between air pollution and crop growth.* For instance, ozone/nitrogen on crop/vegetation growth. Still rather unknown → Type A.



Examples

- *Interaction between climate change and land use.*
 - The importance of representing dynamic vegetation in ES models is well known and it is equally known that human activities play an important role in land use/land cover trends.
 - Interactions might be at local scale (albedo, heat / water exchange processes).
 - Examples: Amazon forest deforestation; monsoon consequences in South Asia.
 - Use various methods: Method A for exploration; Method D for trying to find potential feedbacks.

Land use consistent with temperature?

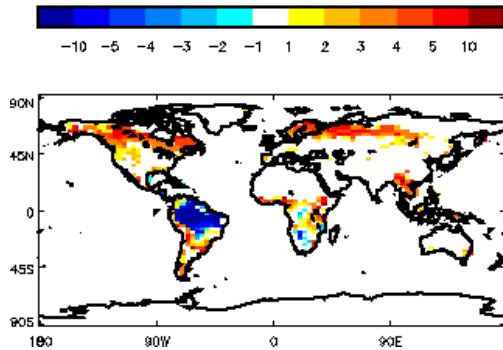

Cox et al. [2000].

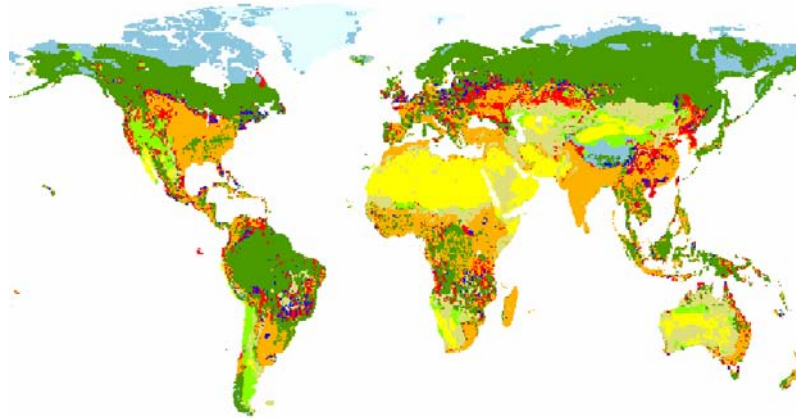

Impact of processes (Albedo) not taken into account in IMAGE

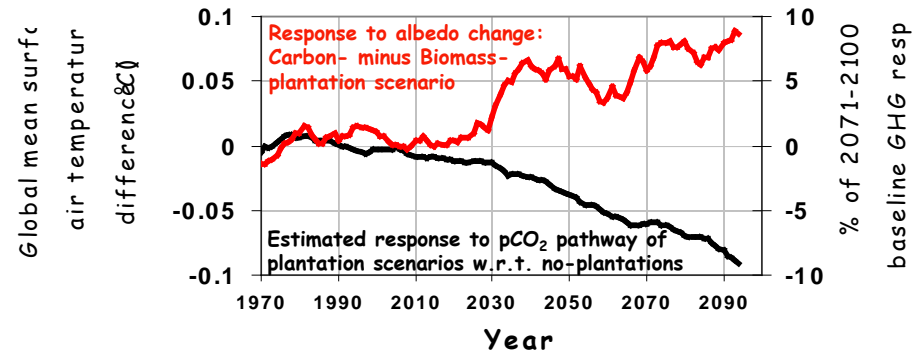
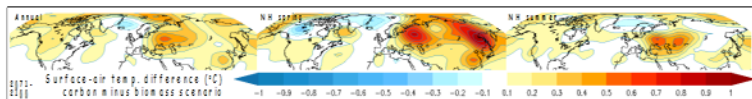
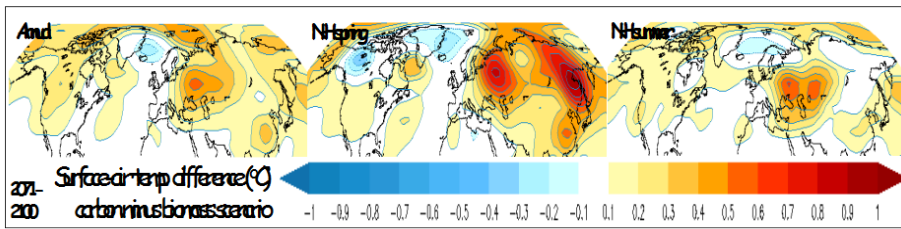

Schaeffer et al



Other examples

- *Interaction between climate policy and air pollution policies*
- *Droughts, availability of water and impacts on societies*
- *Mitigation policy responses to realized/projected climate change*
- *Extreme and catastrophic events*
- *Avoiding particular (regional) climate change outcomes or impacts*



Conclusions

- More cooperation ES / IAM community useful and interesting (better understanding of joint development human / earth system)
- Cooperation can take many different forms – each with strenghts and weaknesses
- Full integration might not always be the best approach (uncertainty; lack of strong feedbacks)
- Full integration in particular useful when local-scale processes become important (poorly represented by IAMs)