



CanESM5 and its contribution to PAMIP

Michael Sigmond
(CCCma, Victoria, BC, Canada)

The role of the basic state
in the response to climate
change and sea ice loss



Canada

CanESM2 (CMIP5)

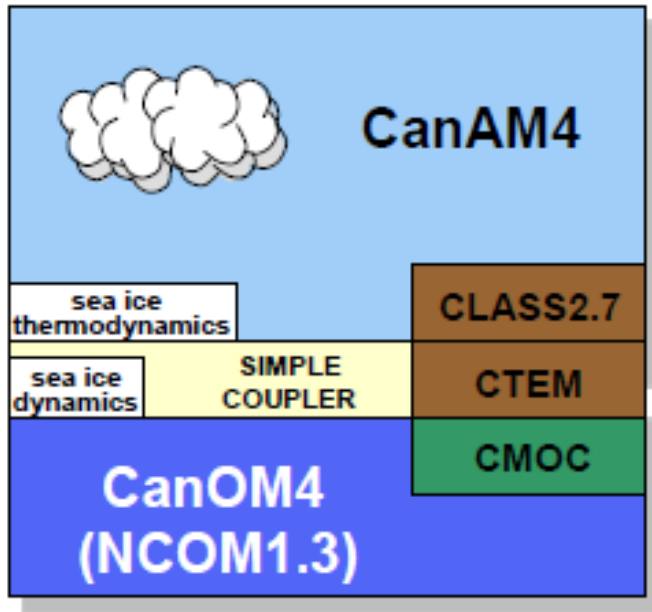

CanESM5 (CMIP6)

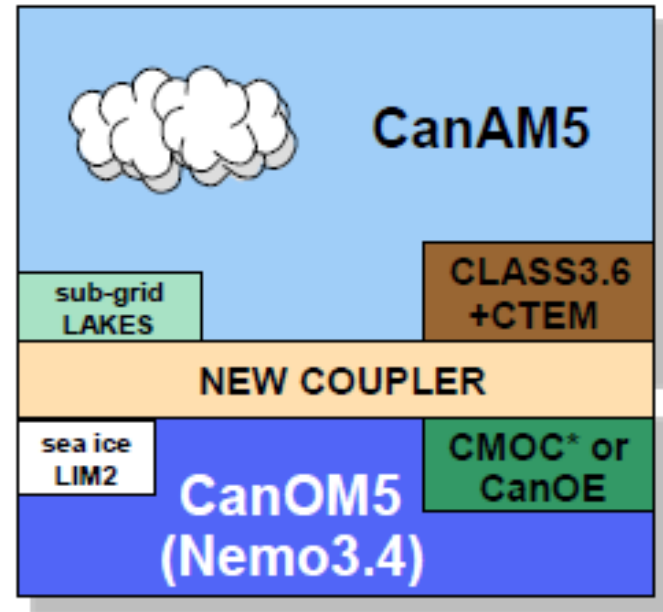

- Next version of CCCma's atmospheric model
 - *radiation, aerosols, snow microphysics, land, lakes*
 - *Same model top (1 hPa) and horizontal resolution (T63), more vertical levels (35 → 49), improved gravity wave settings*
- Completely new ocean and sea ice models (NEMO-LIM2)
developed new coupler from scratch

CanESM5 key characteristics

- Climate sensitivity is higher than CanESM2
(ECS: 3.8K \rightarrow 5.7K , TCS: 2.4K \rightarrow 2.8K)
- RF similar \rightarrow difference due to climate feedbacks (Arctic)
- Sea ice is much more realistic than CanESM2

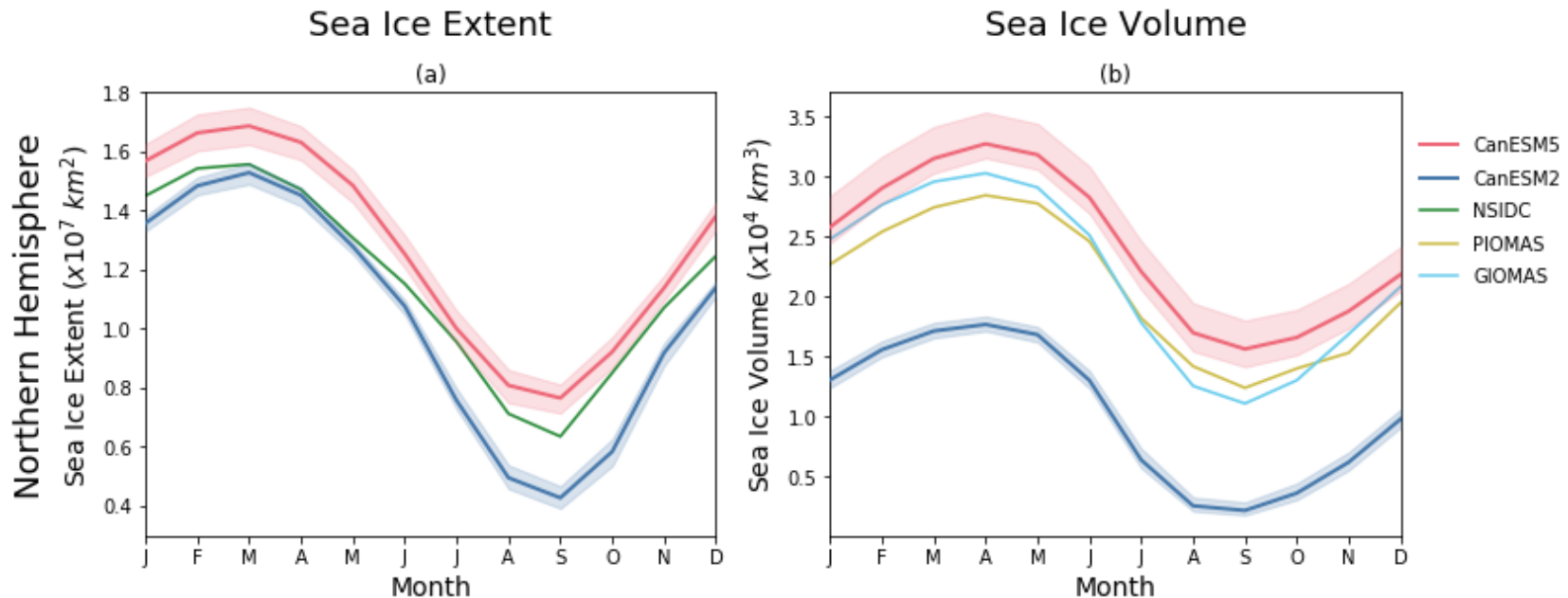

CanESM5 contribution to PAMIP

- Started the runs early June, finished experiments 1.1, 1.5 and 1.6; data will appear on ESGF soon
 - Will do all other AGCM experiments, intent to do all coupled simulations
 - Coupled simulations: nudging in NEMO-LIM2
In assimilation runs: changed SSS of sea ice to avoid crashes
-

CanESM5 response to climate change

NAM (high emissions, 30y running mean)

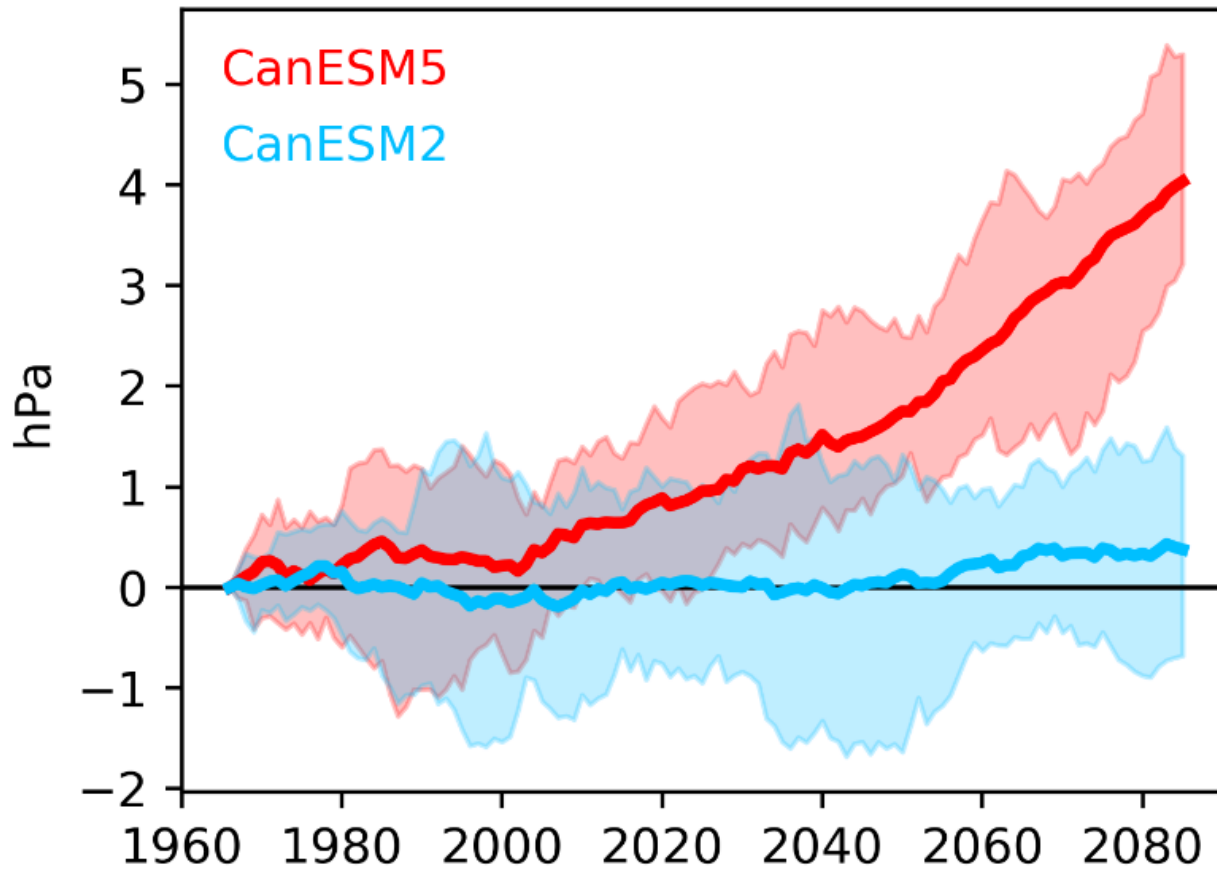

CanESM5 response to climate change

Zonal mean zonal wind (ua) DJF

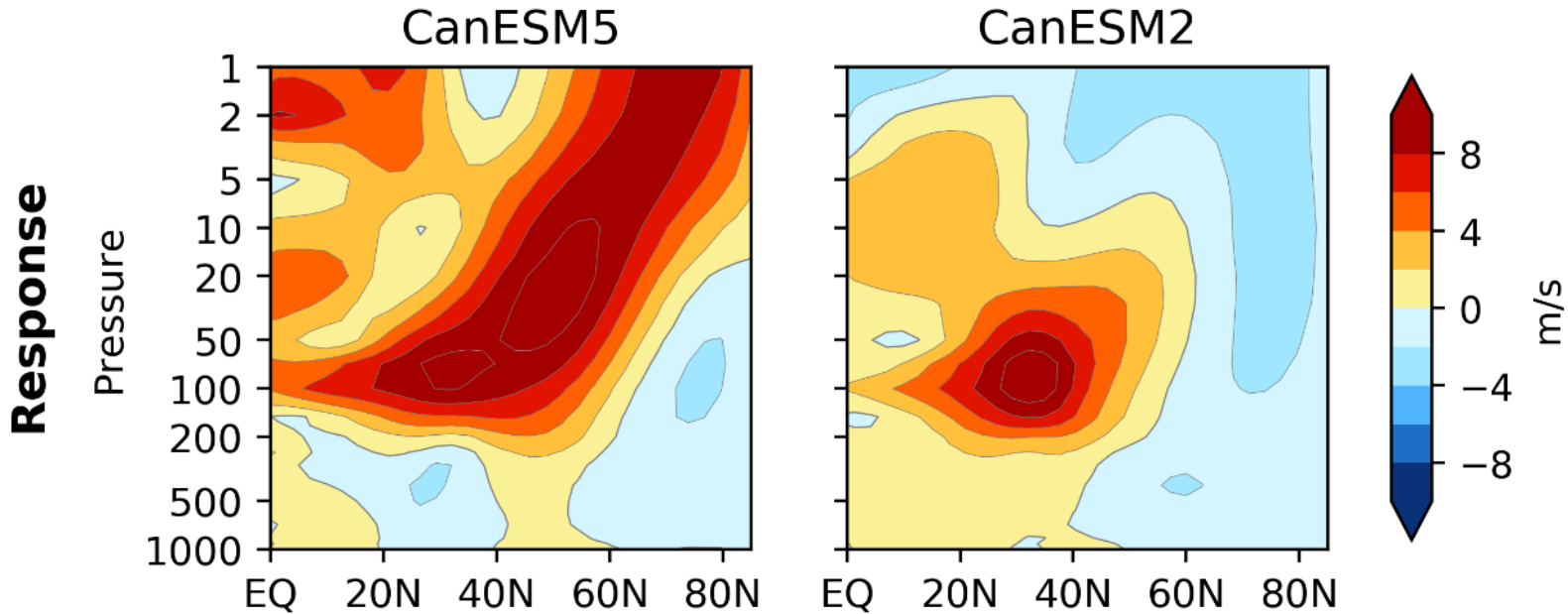

Positive NAM \longleftrightarrow Neutral NAM

- SST/SI response
- Stratospheric resolution
- **Differences in basic state?**

Sigmond et al 2008, Sigmond&Scinocca, 2010:

NAM response to CO₂ doubling depends on basic state (prescribed SST runs)

CanESM5 response to climate change

Zonal mean zonal wind (DJF)

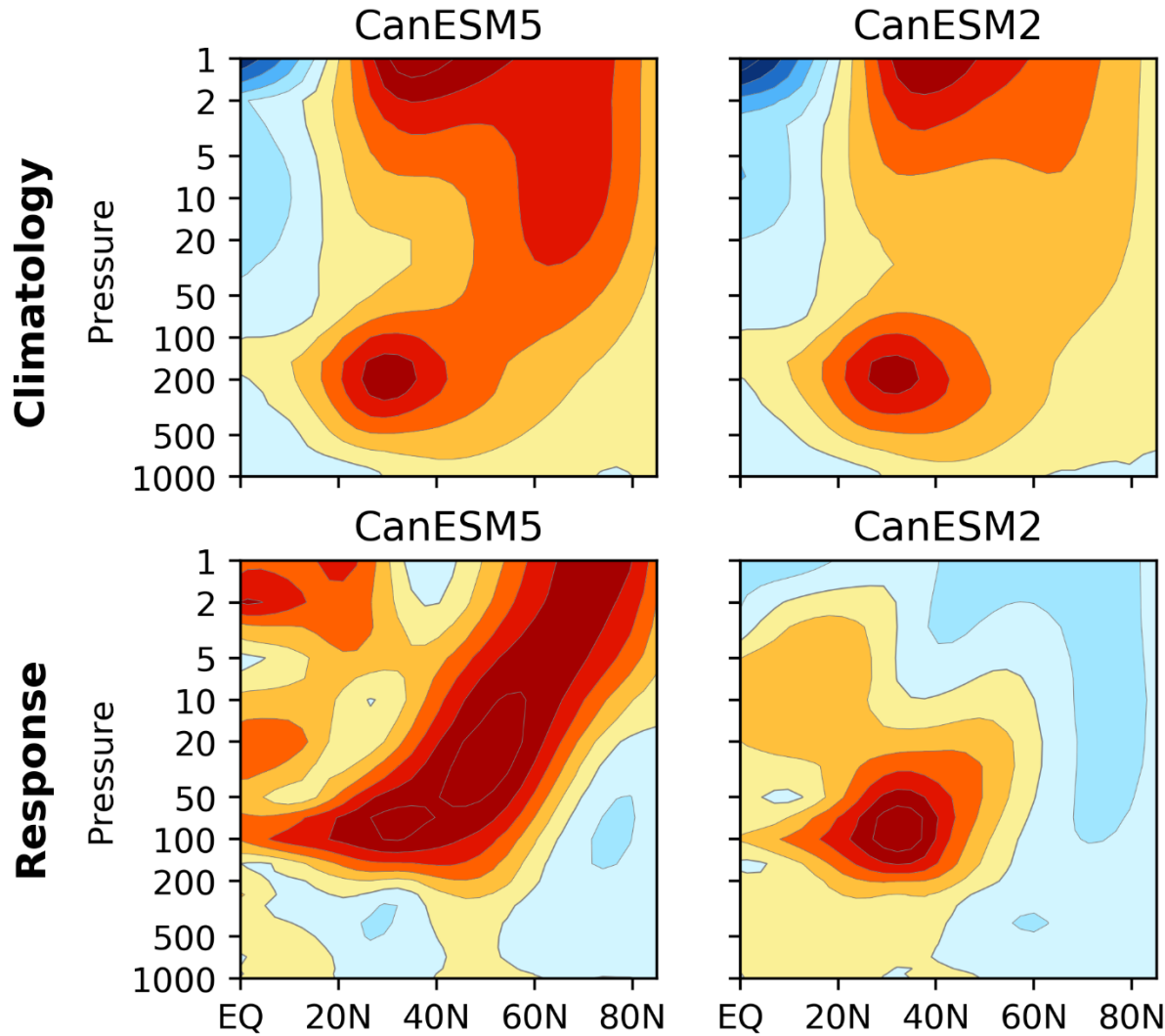

CanESM5 response to climate change

NAM (high emissions, 30y running mean)

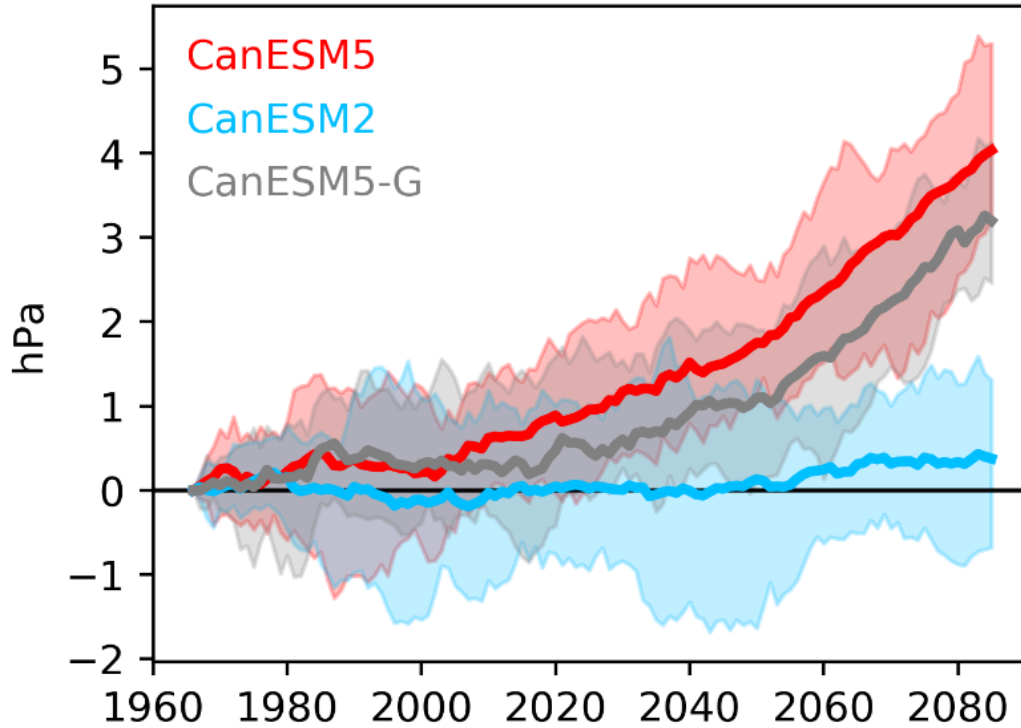

CanESM2:
Neutral NAM



CanESM5:
Positive NAM

- SST/SI response
- Stratospheric resolution
- Different basic state

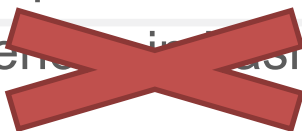

CanAM5 response to future sea ice loss

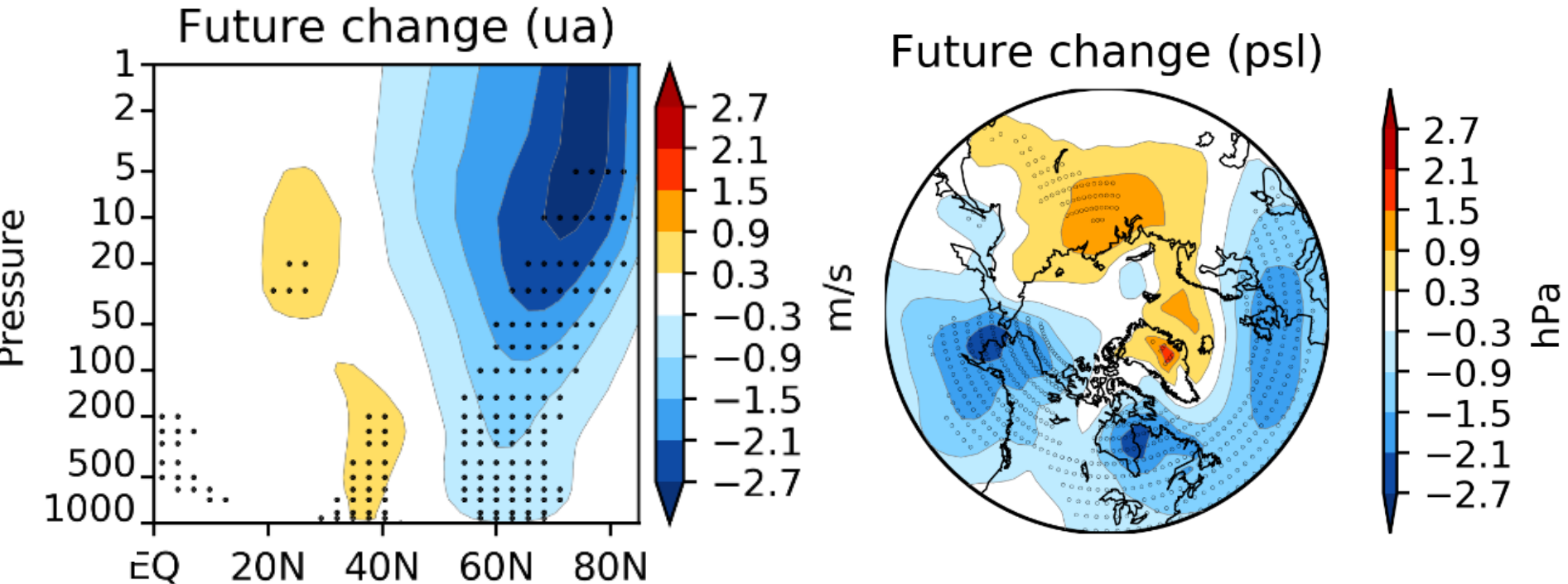

- Smith et al (2017): found dependency on basic state, where basic state differences were between a coupled and uncoupled model (PAMIP exp. 4, Tier 3)
- *But can such a dependency be found in Tier 1 (AMIP) simulations?*

CanAM5 response to future sea ice loss

Dependency on basic state?

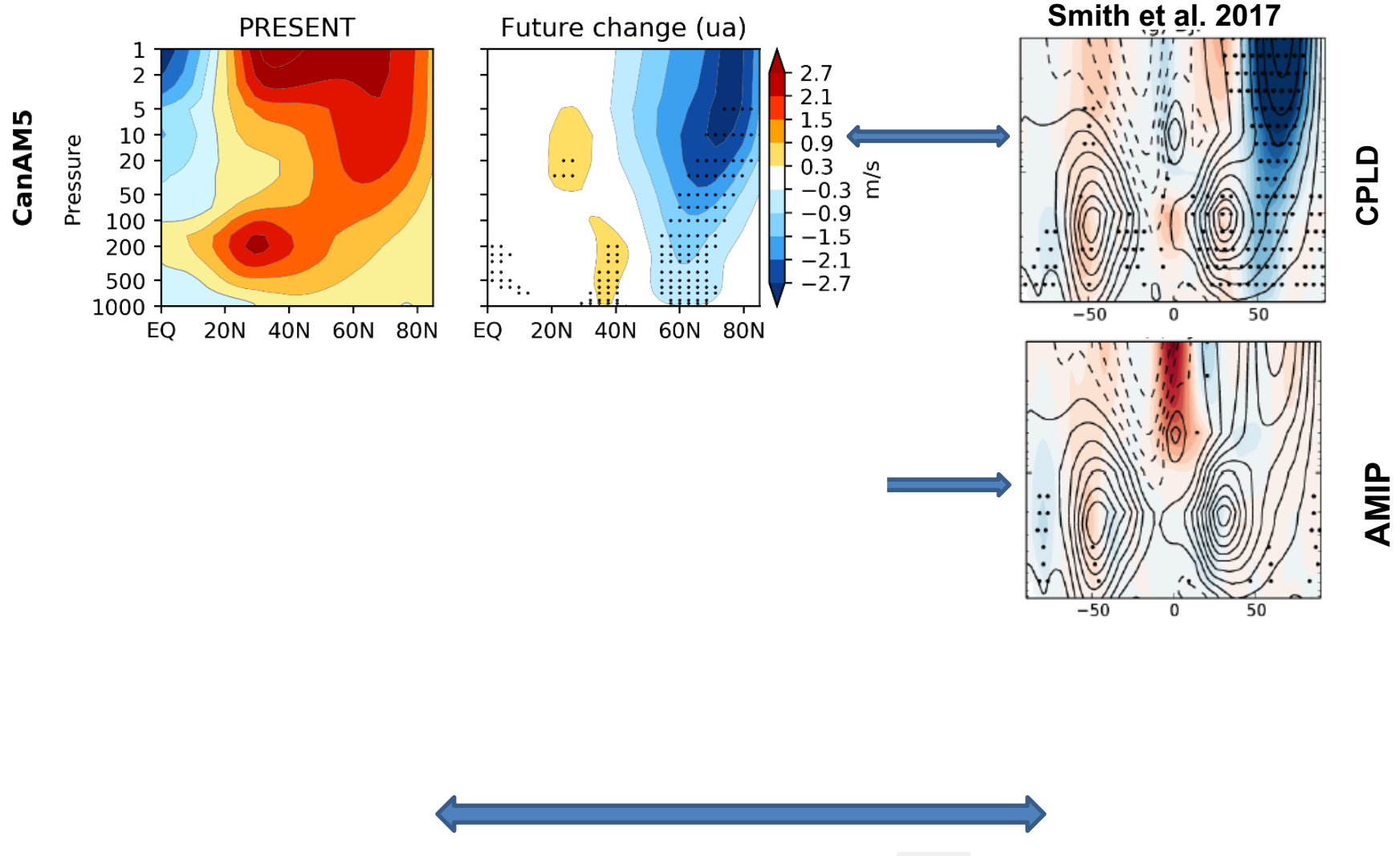

CanAM5 response to future sea ice loss

Dependency on basic state!

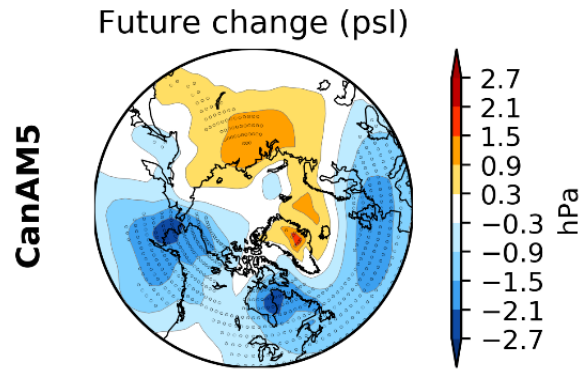

Conclusions:

- **Difference in NAM response to climate change between CanESM2 and CanESM5 not due to basic state, but SST/SI**
- **Response to future SI loss highly dependent on basic state in AMIP experiments**

→ How much of the spread among PAMIP models can be attributed to spread in basic state?

→ Use this spread to observationally constrain response to SI using Tier 1 AMIP experiments?

CanESM5 and CMIP6

- CanESM5 contributes to 20 MIPS, incl. PAMIP& DynVarMIP
 - Relatively coarse resolution → many ensemble members
 - 3 versions:
 - *CanESM5 “p1”*
 - *CanESM5 “p2” [with minor improvements]*
 - *CanESM5-Canoe*
 - PAMIP and DynVarMIP run with the “p2” version
*so look for r*i1p2f1 data!*
 - DynVarMIP variables will be submitted for all p2 runs
-